

Installer Guide

amina S

Intended use

Tiltentkt bruk

amina S is intended for charging electrically powered vehicles equipped with non-gassing batteries. The product must be securely mounted on a sturdy surface. It may only be operated within the approved operating parameters and under specified environmental conditions. Uses other than those specified here are not permitted.

amina S er utelukkende ment for å lade elektriske biler utstyrt med batterier som ikke danner gass. Produktet må monteres forsvarlig på en solid overflate. Det kan bare brukes med godkjente driftsparametre og under de spesifiserte miljøforhold. Annen bruk enn det som er spesifisert her er ikke tillatt.

Table of contents

Innholdsfortegnelse

2

Features
Egenskaper

3

Product overview
Produktoversikt

4

Safety instructions
Sikkerhetsinstruksjoner

5

Installation kit
Installasjonsmaterieil

6

Installation
Installasjon

27

Other languages
Andre språk

Features

Egenskaper

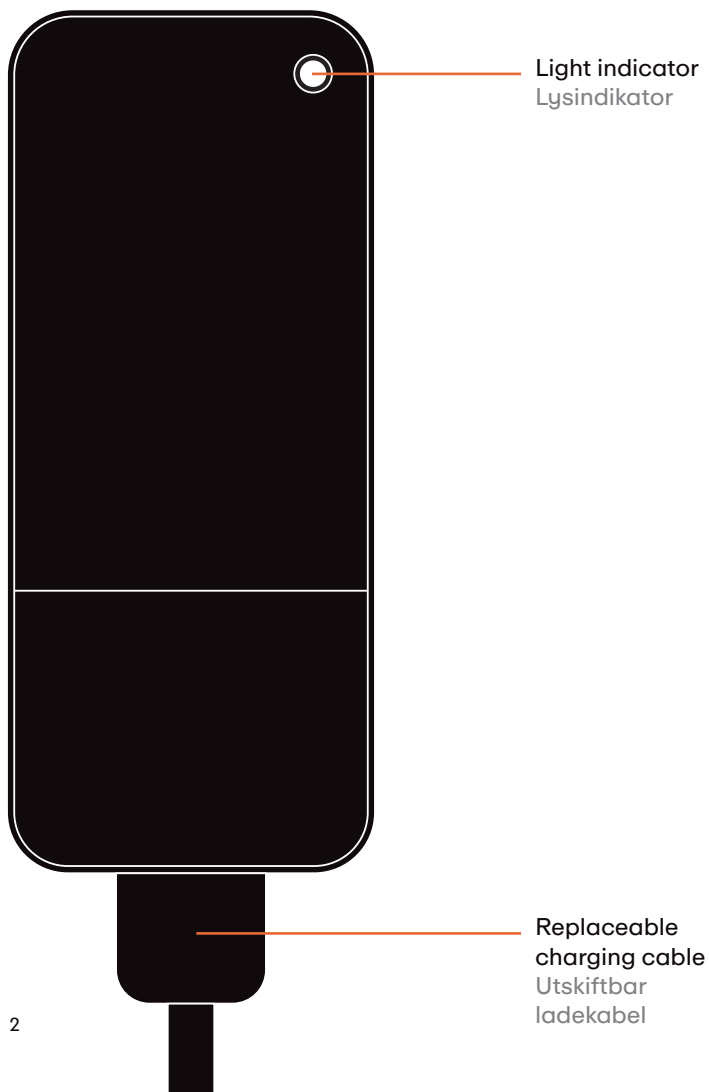

Product overview

Produktoversikt

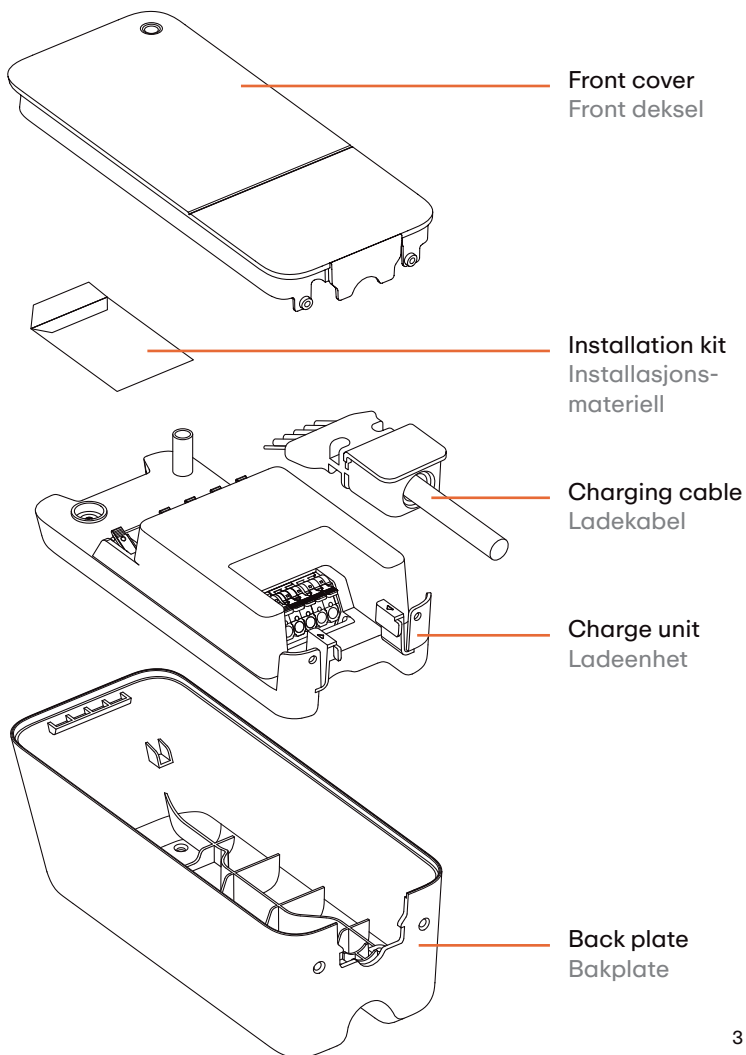

Safety instructions

Sikkerhetsinstruksjoner

Read the entire manual carefully before installing and operating the product.

Observe the following instructions:

- This product must be installed, serviced and repaired by an authorised installer.
- All applicable local, regional and national regulations for electrical installations must be respected and adhered to.
- Do not install a product that is damaged or not functioning properly.
- Do not make any changes to components or connect unofficial charging cables.
- Make sure that the respective circuits are switched off before starting the installation.

Vennligst følg disse instruksjonene:

- Dette produktet må kun installeres, repareres og vedlikeholdes av en autorisert elektriker.
- Alle gjeldende lokale, regionale og nasjonale forskrifter for elektriske installasjoner må respekteres og følges.
- Ikke installer et produkt som er skadet eller ikke fungerer som det skal.
- Gjør ikke endringer på komponenter eller koble til ikke-originale amina ladekabler.
- Sørg for at nødvendige sikringer er skrudd av før installasjonen.

Installation kit

Installasjonsmaterieill

TX20 screw
4 x 35mm
TX20 skrue



x 4

TX20 screw
4 x 12mm
TX20 skrue



x 6

Power cable
grommet
Nippel til
strømkabel



Cable
clamp
Kabel-
klemme



Required for installation

- TX20 screwdriver
- Circuit breaker and external RCD Type A (30mA)

Utstyr til installasjon

- TX20 skrujern
- Overstrømsvern og jordfeilvern Type A

1

Disassemble charger.

Lift off front cover. (1)

You will find a bag of installation accessories inside the charger.

Remove charge unit by gently pinching and pulling the tabs at the bottom. (2)

Demonger laderen.

Løft av frontdekselet. (1)

Du vil finne en pose med installasjonsmateriell inne i laderen.

Fjern ladeenheten ved å forsiktig klemme sammen og dra ut klemmene i bunnen av ladeenheten. (2)

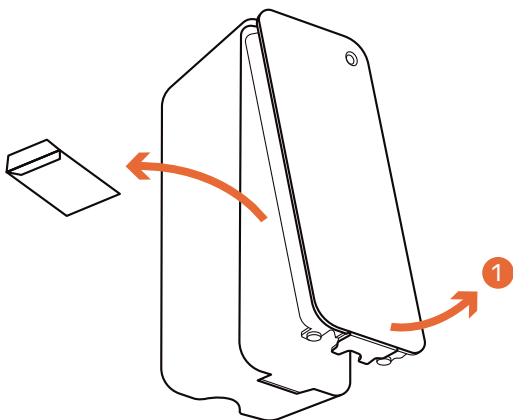

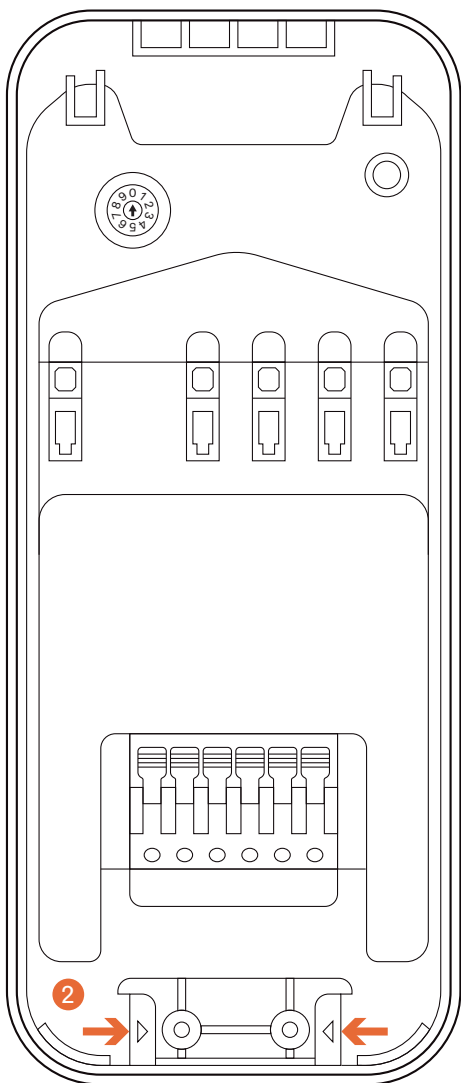

2

Mount back plate.

Attach the back plate to a sturdy surface minimum 90cm above ground using the supplied 35mm screws. Optional screw holes are located at the top and bottom of the back plate. (1)

Monter bakplaten.

Monter laderen på en solid overflate minst 90cm over bakken med de inkluderte fire 35mm skruene. Det er 2 valgfrie hull for skruer, oppe og nede på bakplaten. (1)

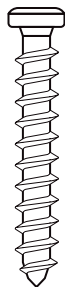

x 4

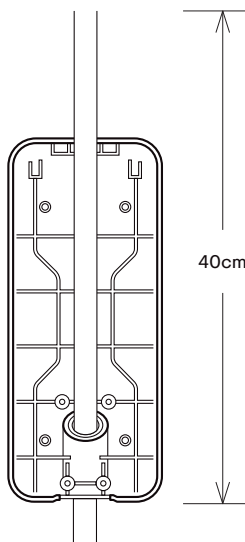

Reminder:
Make sure you cut the cable at least 40cm from the inlet hole.

Tips:
Det trengs minimum 40cm kabel fra inntakshullet.

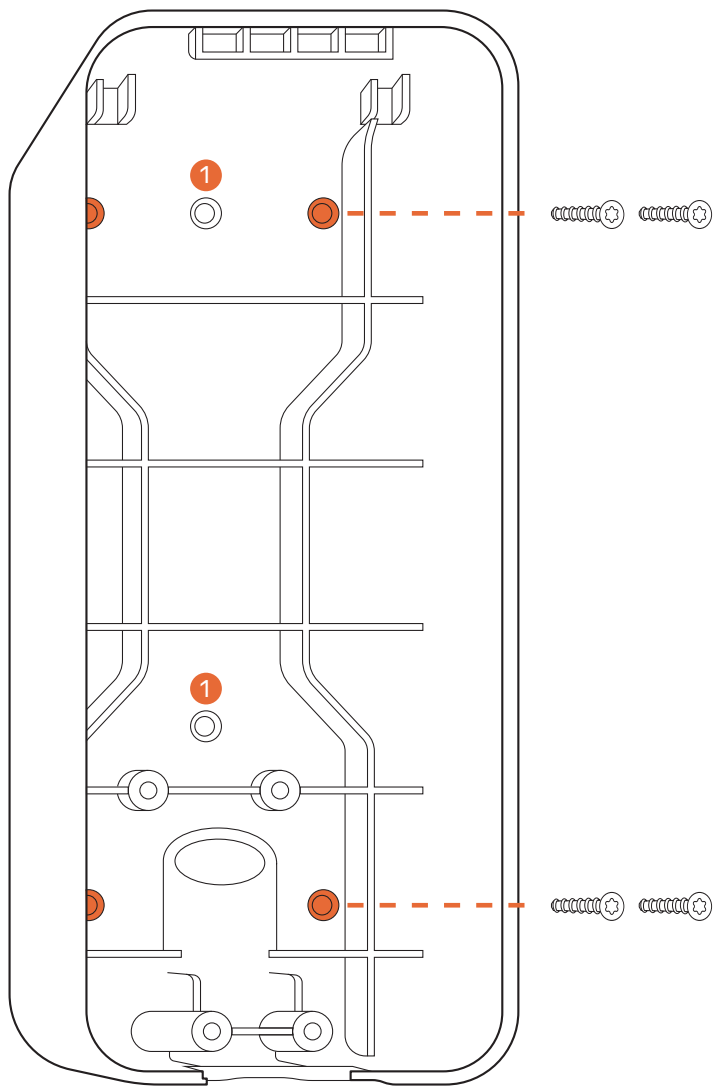

3

Install power cable.

Slide the grommet down the power cable to seal the inlet-hole in the back plate.

Installer strøm kabel.

Skyv nippelen nedover strømkabelen til den dekker inntakshullet

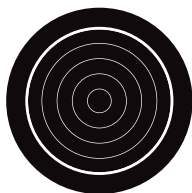

x 1

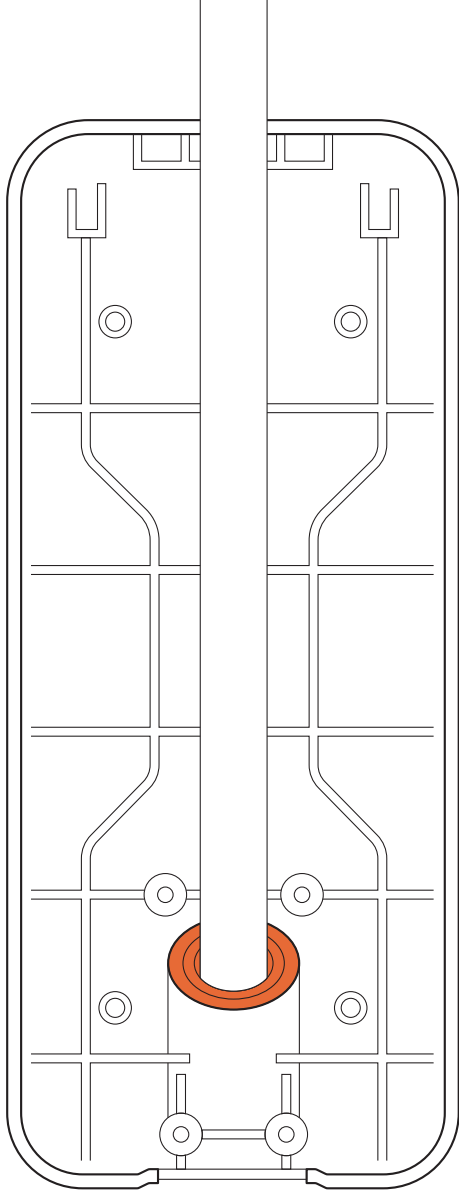

4

Prepare and secure power cable.

Strip power cable about 10cm over the inlet hole. (1)

Secure cable with the supplied cable clamp and two 12mm screws. (2)

Forbered og fest installasjonskabel.

Avisoler kablen ca. 10cm over inntakshullet. (1)

Fest kablen med kabelklemmen og to 12mm skruer. (2)



x 1



x 2

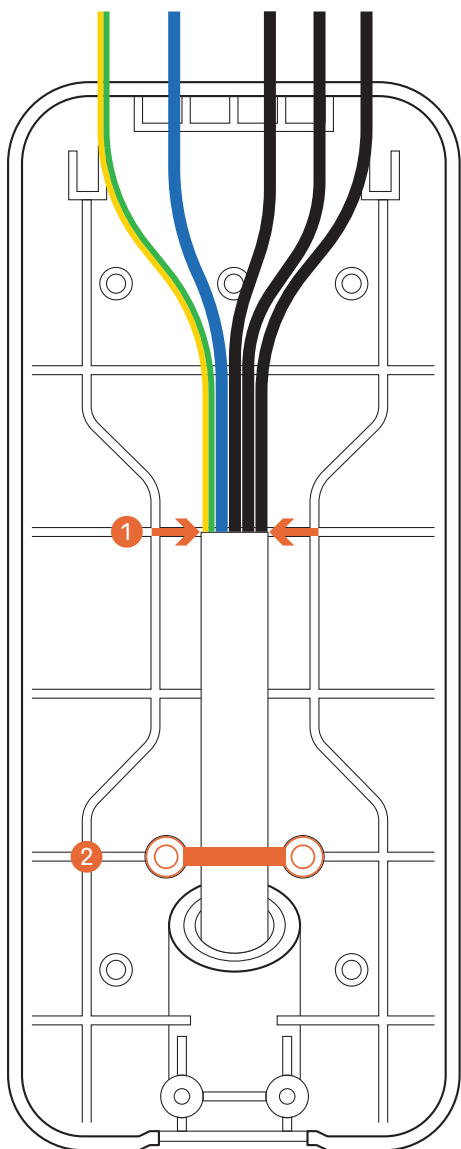

5

Insert the charge unit.

Insert the upper part of the charge unit under notches in the back plate. (1)

Push the lower part of the charge unit toward the back plate until it clips in. (2)

Sett inn ladeenhet.

Sett øverste del av ladeenheten under de to hakkene i øverste del av bakplaten. (1)

Trykk nederste del av ladeenheten inn mot bakplaten til den klikker på plass. (2)

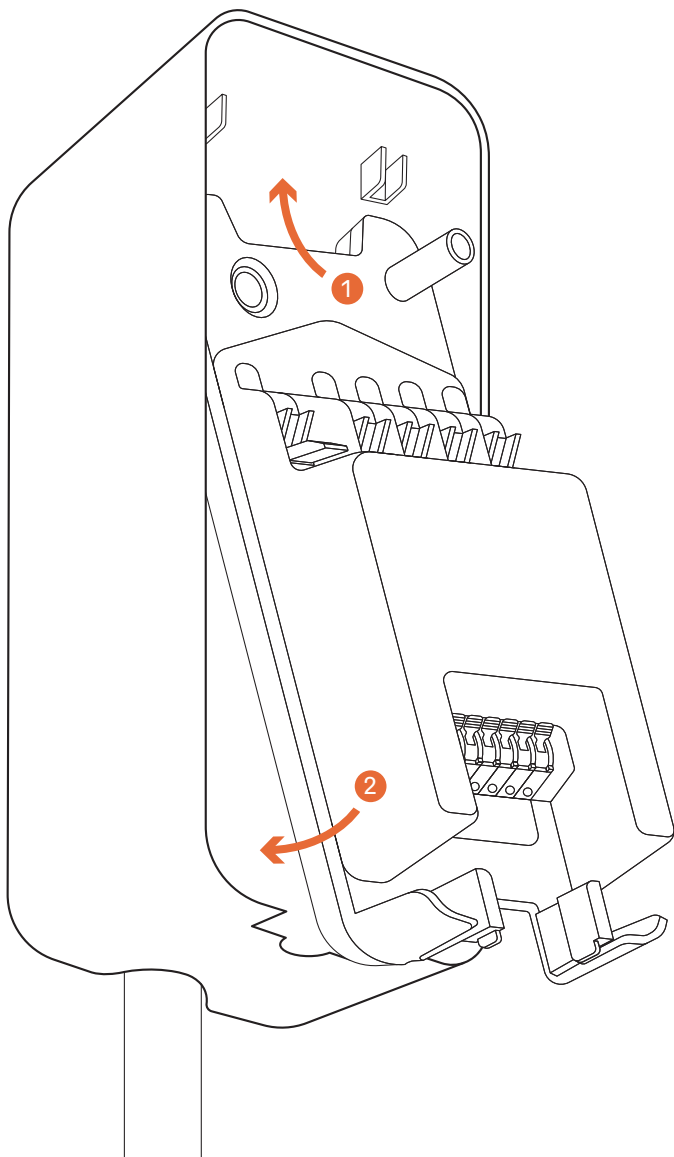

6

Connect power cable.

Cut and peel each wire to length and insert in to the appropriate connectors. Snap shut all levers.

Koble strøm kabel.

Kutt og skrell hver leder til passende lengde og sett dem inn i koblingene. Lås deretter alle koblingene.

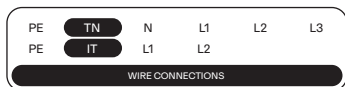

Note:

The charger is designed to accept wires with a cross section from 1,5mm² to 6mm².

Obs:

Laderen er designet for strømledere fra 1,5mm² til 6mm².

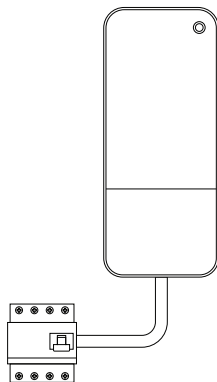

Remember using an external RCD type A.

Husk å bruke en eksternt jordfeilvern type A.

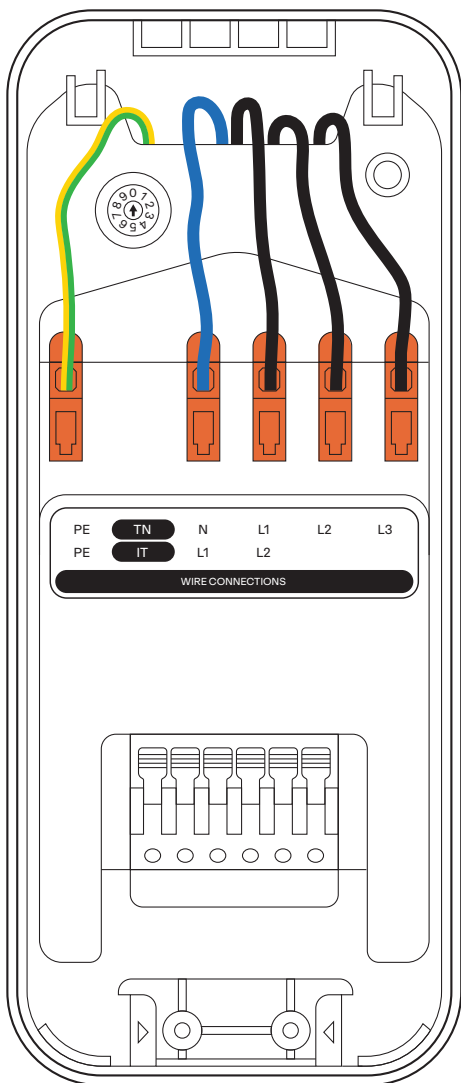

7

Install charging cable.

Open wire terminals and insert charging cable wires. (1)

Push the strain relief onto the back plate until it is in a vertical position. (2)

Snap shut all 6 levers. (3)

Secure charging cable to the back plate using two 12mm screws. (4)

Installer ladekabelen.

Åpne terminalene og sett inn strømlederne fra ladekabelen. (1)

Skyv strekkavlasteren mot bakplaten til den står vertikalt. (2)

Fest alle 6 koblinger. (3)

Fest så ladekabelen til bakplaten med to 12mm skruer. (4)



x 2

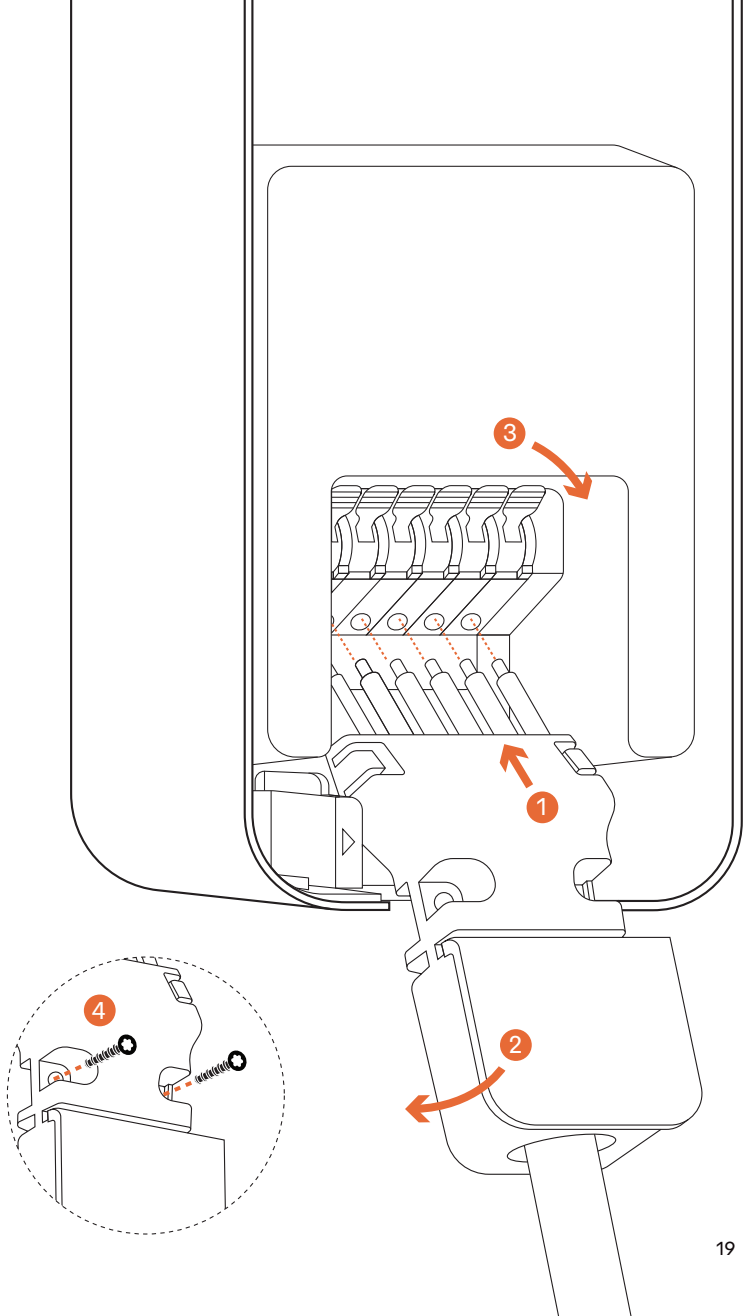

8

Set charging current.

Set maximum amperage at the top left corner of the charge unit.

Sett ladestrøm.

Sett maksimum ladestrøm i øvre venstre hjørne av ladeenheten.

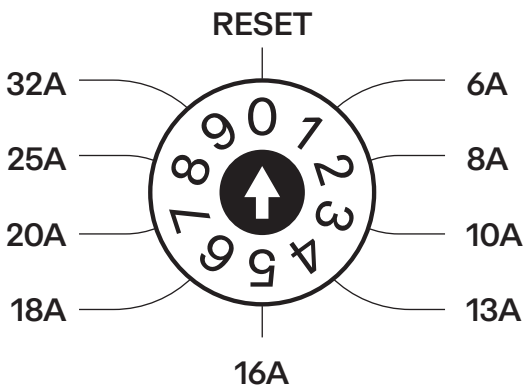

Note:

Changes to current settings will not take effect until power has been cycled off and on.

Merk:

Endringer på ladestrøm vil først tre i kraft etter at strømmen har blitt slått av og på igjen.

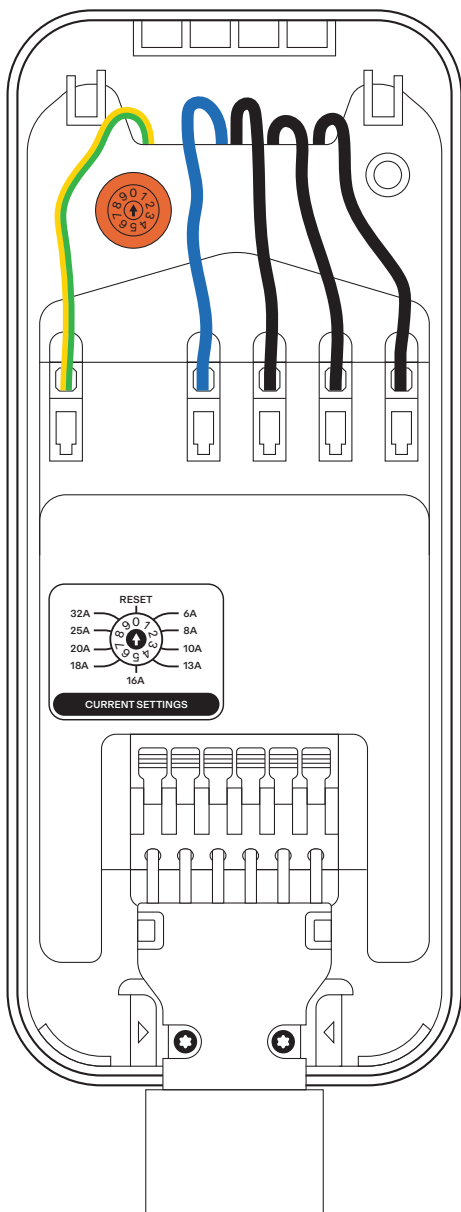

9

Mount front cover.

Slide the upper part of the cover under the lip at the top (1) and push in the lower section. (2)

Secure the cover with two 12mm screws. (3)

Monter frontdeksel.

Skyv øverste del av dekselet under leppen i toppen (1) og press inn nederste del. (2)

Fest dekselet med to 12mm skruer. (3)



x 2

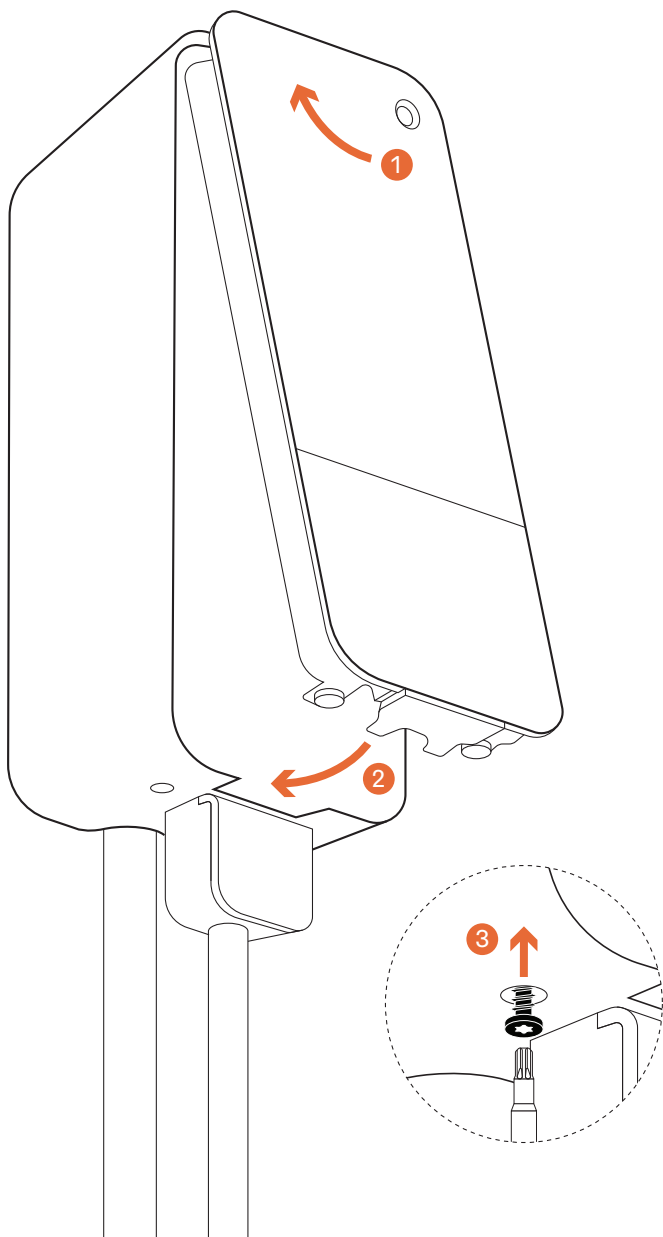

10

Test and finish installation.

Switch on the circuit breaker.

Steady white light indicates correct installation.

We recommend testing the charger with an applicable test tool.

An overview of light indicator colors can be found in the User guide.

Test og fullfør installasjonen.

Skru på strømmen.

Hvitt lys indikerer korrekt installasjon.

Vi anbefaler test av laderen med et testverktøy.

Oversikt over lysindikasjon farger finnes i brukermanualen.

Quick tip:

If the charger is blinking white, set correct amperage. See step 8.

Tips:

Hvis laderen blinker hvitt, sett korrekt ladestrøm. Se punkt 8.

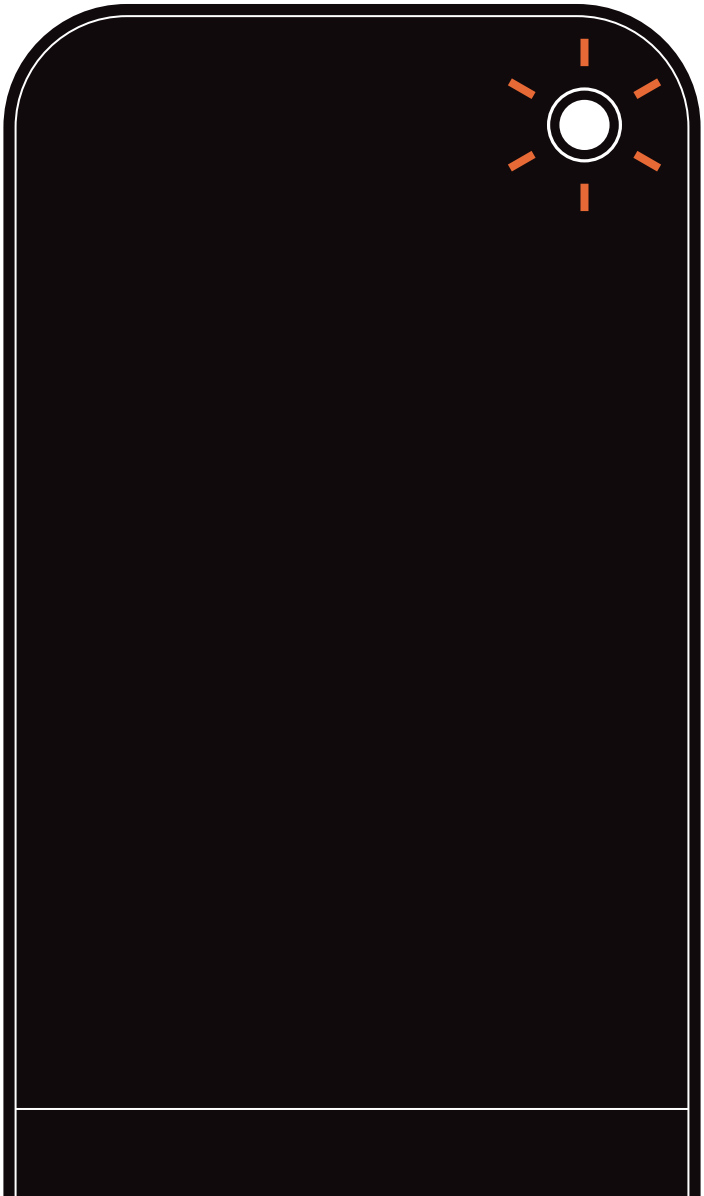

Notes:
Notater:



Other languages

This installation guide is available in multiple languages at download.aminacharging.com



Manufactured by:
amina distribution AS
Grenseveien 21
4313 Sandnes Norway

